

DOCERAM  
ADVANCED CERAMIC SOLUTIONS

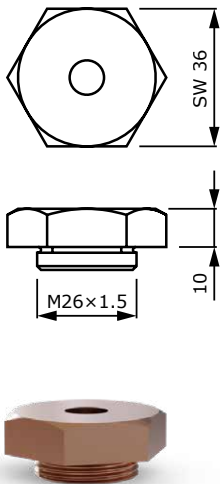

Cerazur

CSERÉLHETŐ ELEKTRODÁK

LEMEZ FURAT ØD	SW 36	LEMEZ FURAT ØD	SW 36
11.0	1111-ZK-20166	12.3	1111-ZK-20179
11.1	1111-ZK-20167	12.4	1111-ZK-20180
11.2	1111-ZK-20168	12.5	1111-ZK-20181
11.3	1111-ZK-20169	12.6	1111-ZK-20182
11.4	1111-ZK-20170	12.7	1111-ZK-20183
11.5	1111-ZK-20171	12.8	1111-ZK-20184
11.6	1111-ZK-20172	12.9	1111-ZK-20185
11.7	1111-ZK-20173	13.0	1111-ZK-20186
11.8	1111-ZK-20174	13.1	1111-ZK-20187
11.9	1111-ZK-20175	13.2	1111-ZK-20188
12.0	1111-ZK-20176	13.3	1111-ZK-20189
12.1	1111-ZK-20177	13.4	1111-ZK-20190
12.2	1111-ZK-20178	13.5	1111-ZK-20191



RÖVID

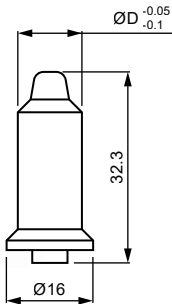

HOSSZÚ

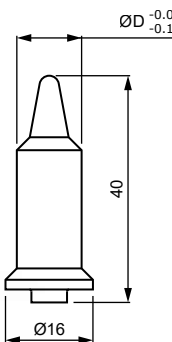

GALLÉROS

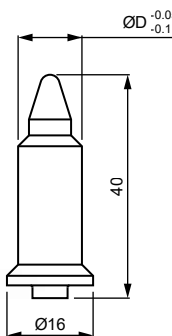

CERAZUR KERÁMIA TÁJOLÓCSAPOK

LEMEZ FURAT ØD	RÖVID	HOSSZÚ	GALLÉROS
11.0	8228-ZK-11079	8228-ZK-10079	8228-ZK-10379
11.1	8228-ZK-11080	8228-ZK-10080	8228-ZK-10380
11.2	8228-ZK-11081	8228-ZK-10081	8228-ZK-10381
11.3	8228-ZK-11082	8228-ZK-10082	8228-ZK-10382
11.4	8228-ZK-11083	8228-ZK-10083	8228-ZK-10383
11.5	8228-ZK-11084	8228-ZK-10084	8228-ZK-10384
11.6	8228-ZK-11085	8228-ZK-10085	8228-ZK-10385
11.7	8228-ZK-11086	8228-ZK-10086	8228-ZK-10386
11.8	8228-ZK-11087	8228-ZK-10087	8228-ZK-10387
11.9	8228-ZK-11088	8228-ZK-10088	8228-ZK-10388
12.0	8228-ZK-11089	8228-ZK-10089	8228-ZK-10389
12.1	8228-ZK-11090	8228-ZK-10090	8228-ZK-10390
12.2	8228-ZK-11091	8228-ZK-10091	8228-ZK-10391
12.3	8228-ZK-11092	8228-ZK-10092	8228-ZK-10392
12.4	8228-ZK-11093	8228-ZK-10093	8228-ZK-10393
12.5	8228-ZK-11094	8228-ZK-10094	8228-ZK-10394
12.6	8228-ZK-11095	8228-ZK-10095	8228-ZK-10395
12.7	8228-ZK-11096	8228-ZK-10096	8228-ZK-10396
12.8	8228-ZK-11097	8228-ZK-10097	8228-ZK-10397
12.9	8228-ZK-11098	8228-ZK-10098	8228-ZK-10398
13.0	8228-ZK-11099	8228-ZK-10099	8228-ZK-10399



Megrendelésre Volcera anyagból készült tájolócsapokat is szállítunk.  
Termékkód: „8440-ZK-xxxxx” (az „xxxxx” a táblázatban szereplő  
termékek utolsó öt számával azonos, pl. Ø11.0-nál a kód 8440-ZK-11079)

### ELEKTRODATARTÓK

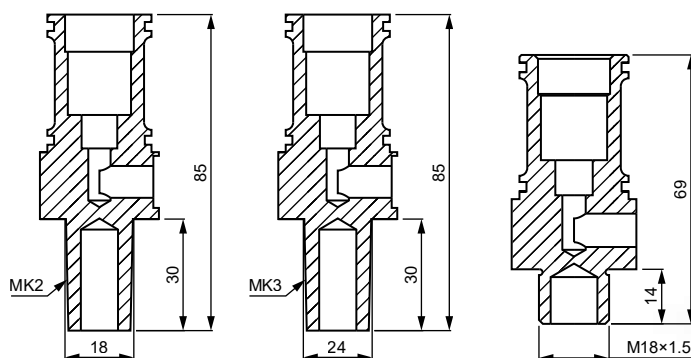

ANYA MÉRET	MK2 KÚP	MK3 KÚP	M18x1.5 MENET
M10	1111-ZK-20544	1111-ZK-20545	1111-ZK-20563

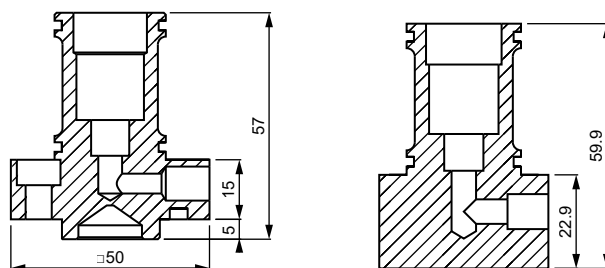

ANYA MÉRET	R-TÍPUS	C-TÍPUS
M10	1111-ZK-10644	1111-ZK-10663

### HŰTŐ GYŰRŰ

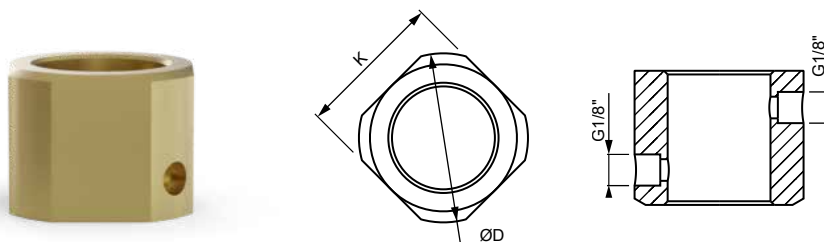

ANYA MÉRET	MEGJELÖLÉS	ØD	K
M10 – M12	1113-ZK-19767	52	46
C-típus M10 – M12	1113-ZK-19769	52	46

### TARTOZÉKOK ELEKTRODATARTÓKHOZ

RUGÓ



TARTÓ HOSSZ	MEGJELÖLÉS
40 mm-tól	1112-ZK-12207

O-GYŰRŰ



TYP DRŽIACA	MEGJELÖLÉS
Ø34	1123-ZK-26187

GYORSCSATLAKOZÓ



—	MEGJELÖLÉS
sűrített levegő bevezető G1/8"-Ø6	1116-ZK-12353

DOCCERAM  
ADVANCED CERAMIC SOLUTIONS

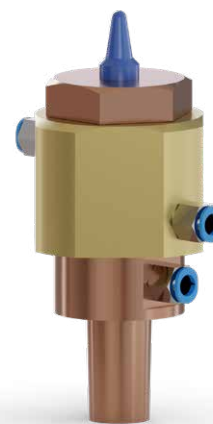

CSERÉLHETŐ  
ELEKTRODA

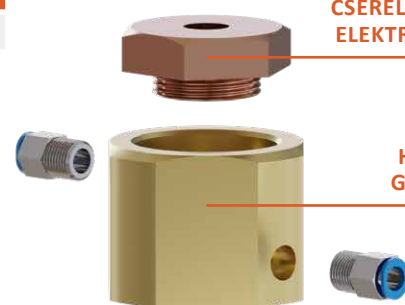

HŰTŐ  
GYŰRŰ

TÁJOLÓCSAP



RUGÓ



ELEKTRODA  
TARTÓ  
O-GYŰRŰKKEL



GYORSCSATLAKOZÓ  
SŰRÍTETT  
LEVEGŐRE

