

Mig / Mag Torch

High Performance Air-Cooled 250 Amp. Mig Torch

ProSpot

welding & joining technologies

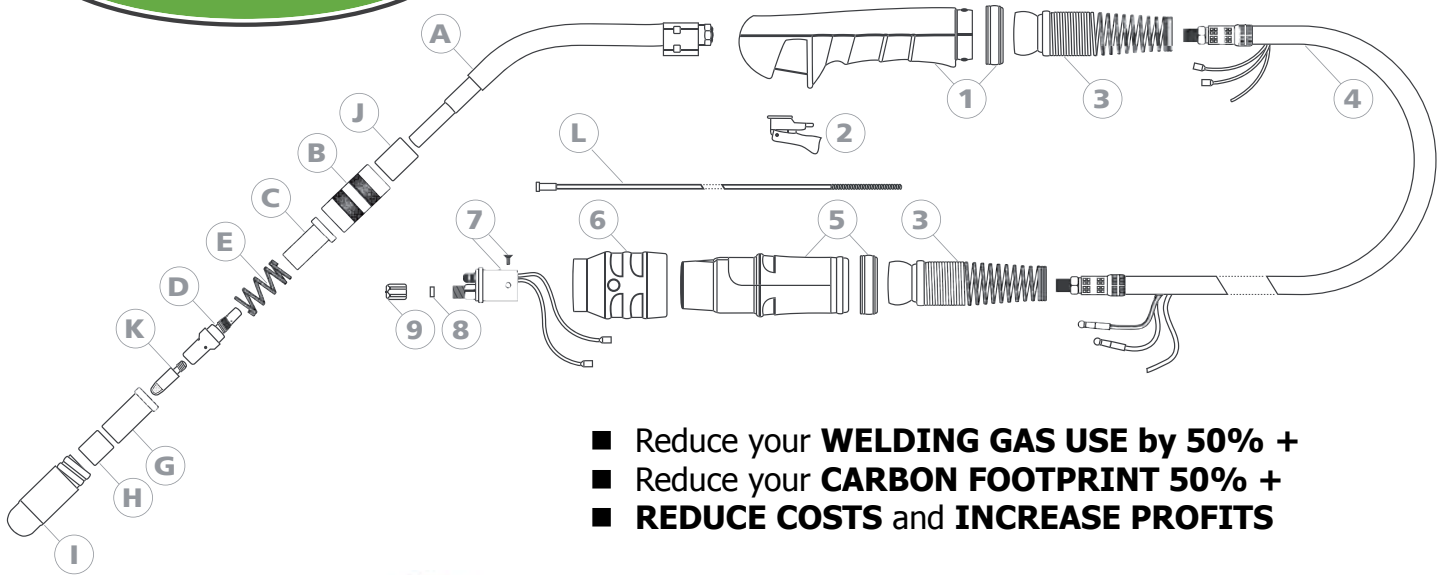

- Reduce your **WELDING GAS USE** by 50% +
- Reduce your **CARBON FOOTPRINT** 50% +
- **REDUCE COSTS** and **INCREASE PROFITS**



5L/mn

Parts & Components

P/N	Description
1	NPT Handle (with ring, without Trigger)
2	GN Trigger for Handle
A	1110 Swan Neck for 250
B	1121 Shroud retainer for 250
C	1130 Insulation Spring 250
D	1140 Gas Tip Adaptor for 250
E	1150 Spring
G	1170.2 Insulation Bush for 250
H	1170.1 Ceramic Bush for 250
I	1181 Shroud for 250
J	1160 Insulation Ring for 250 Swan Neck
K	108 Contact Tip M6 — 0,8 mm
K	110 Contact Tip M6 — 1 mm
K	112 Contact Tip M6 — 1,2 mm

Torches

TM2503	250 Amp. Redux MIG Torch - 3 m
TM2504	250 Amp. Redux MIG Torch - 4 m
TM2505	250 Amp. Redux MIG Torch - 5 m

P/N	Description
L	GM510 Guide Spiral liner 1,0-1,2 — 3 m
L	GM511 Guide Spiral liner 1,0-1,2 — 4 m
L	GM512 Guide Spiral liner 1,0-1,2 — 5 m
L	GM600 Guide Spiral liner Ptfе 1,0-1,2 — 3 m
L	GM601 Guide Spiral liner Ptfе 1,0-1,2 — 4 m
L	GM602 Guide Spiral liner Ptfе 1,0-1,2 — 5 m
3	NTRR Cable Support Spring
4	CC25xM Power Cable (3m / 4m / 5m)
5	NTCC Rear connector (with ring)
6	NTBDF Coupling Cap
7	NTCA Central Adaptor + Pan Head Screw
8	NTPBF Teflon® Ring
9	NTBFP Coupling Nut (long)



Prospot Limited - Unit C Riverside Industrial Estate
 Atherstone Street - Fazeley - Tamworth - Staffordshire - B78 3RW
 Telephone: 01827 254 829 - Fax: 01827 254 832
 Email: sales@prospot.co.uk - Web: www.prospot.co.uk